

Weatherproof



HD-SB525HL

General Features

- * 5th Generation DSP Chip
- * 1/3" Sony 960H CCD
- * No Noise, Ghosting Effect with DNR
- * 3D-DNR(Digital Noise Reduction)
- * ø5 IR LED Built-in 24pcs
- * 0Lux(IR LED On)

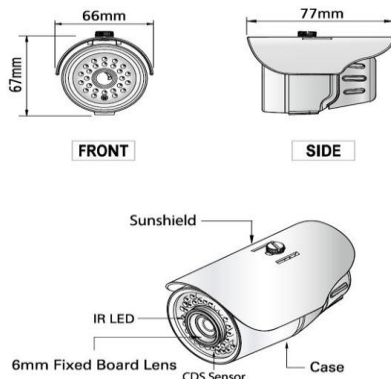

SPECIFICATIONS

MODEL	HDPRO HD-SB525HL
Image Pick-Up Device	1/3" Sony 960H CCD
TV System	NTSC, PAL
Total Pixels	NTSC=1020(H) * 508(V) / PAL=1020(H) * 596(V)
Effective Pixels	NTSC=976(H) * 494(V) / PAL=976(H) * 582(V)
Scanning System	2:1 Interlace
Synchronization	Internal
Resolution	700TV Lines
S/N (Y signal)	52dB
Minimum Illumination	0Lux(IR LED ON)
White Balance	ATW
Electronic Shutter Speed	AUTO / (1/50SEC, 1/60SEC~ 1/100,000SEC)
Sense-Up	On
Gain Control	Middle
3 DNR	3D-DNR
D&N Selection	Auto
Power Supply	DC 12V
Power Consumption	IR LED ON:700mA Max
Lens	6mm Fixed Board Lens
Operational Temp.	-10 ~ +50 Deg C. RH 95% Max.
Storage Temp.	-20 ~ +60 Deg C. RH 95% Max.
Dimension	66mm(W) * 67mm(H) * 77mm(D)
Weight	700g



YOUR'S SMART SECURITY PROVIDER

GENX TECHNOLOGY (M) SDN BHD

NO.68-2, JALAN DWITASIK, DATARAN DWITASIK, BANDAR SRI PERMAISURI, 56000 KUALA LUMPUR, MALAYSIA
TEL: 03-9171 1988 FAX:03-9171 4988

